

HAKI Lattice Beam 450 AL

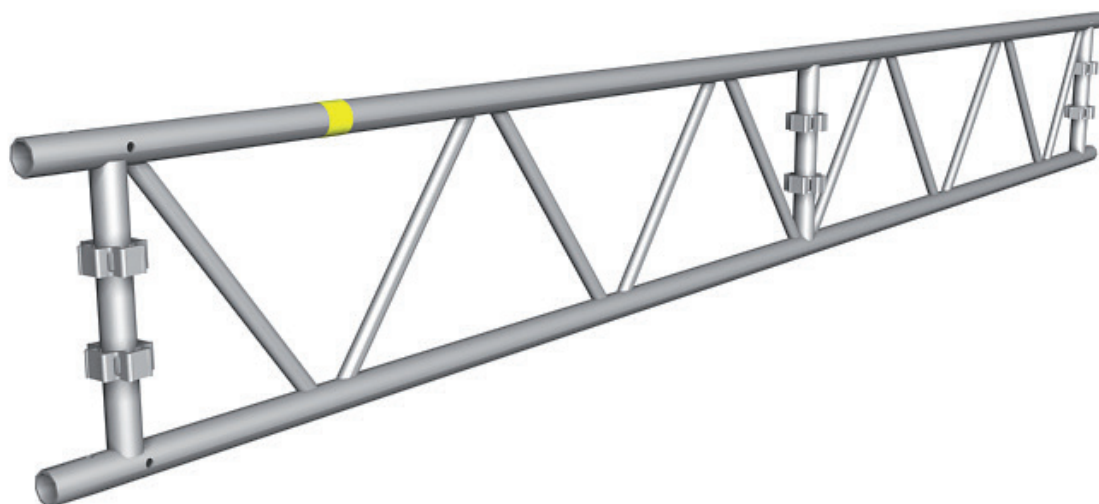

Lattice Beam 450 AL	Item No.	Weight [kg]	Holes
FB 2220 AL	4032211	9.9	4
FB 4100 AL	4032411	17.8	6
FB 6100 AL	4032611	25.8	8
FB 8100 AL	4032811	34.0	10

HAKI Lattice Beam 450 is originally designed for the HAKITEC weather protection and cladding system, but can also be used as a lattice beam in scaffolding. The lattice beam is to be assembled so that the yellow decal is pointing upwards, towards the ridge.

- Optimised design
- Pockets on the verticals to ease the fitting of stiffening ledger beams
- Holes on the upper tube to speed up the fixing of track saddle clamps
- Rigid joints using single ridge connectors and spring clips
- Calculated according to EN 12811

Permitted loads HAKI Lattice Beam 450 AL

The loads below apply when the lattice beam is used as a work platform. The lattice beam shall be braced against lateral instability on fastenings and at least every second metre. Use lattice beam LBL as bracing.

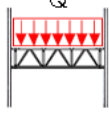
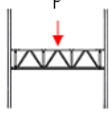
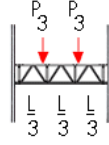
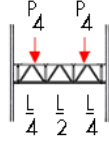
							
Distance support L [m]	Permissible load q [kN/m]	Permissible distributed load Q [kN]	Permissible Centre point load P [kN]	Permissible point loads P ₃ [kN]	Permissible point loads P ₄ [kN]		
4	4.9	19.4	7.5	7.5	7.5		
5	3.9	19.4	7.5	7.5	7.5		
6	3.0	18.3	7.5	6.9	7.5		
7	2.2	15.7	7.5	5.9	7.5		
8	1.7	13.7	6.9	5.1	6.9		
9	1.4	12.2	6.1	4.6	6.1		
10	1.1	11.0	5.5	4.1	5.5		
11	0.9	10.0	5.0	3.7	5.0		
12	0.8	9.1	4.6	3.4	4.6		
13	0.6	8.4	4.2	3.2	4.2		
14	0.6	7.8	3.9	2.9	3.9		

1 kN = 100 kp

Max bending moment: 13.7 kNm
 Max shear force: 9.7 kN

Note.:

Concentrated load distribution = 50 mm.

All load instances included the beam's self-weight.

For concentrated loads on joints, contact HAKI's technical department.

