

USER'S MANUAL

HAKI PUBLIC ACCESS

STAIR

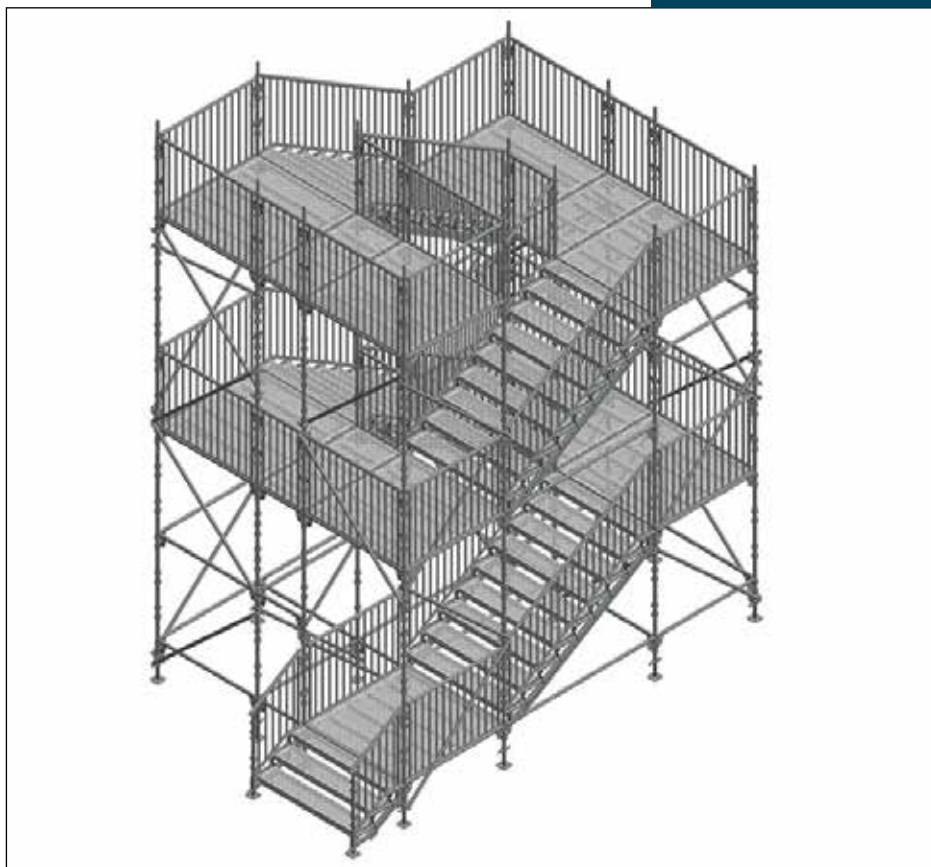

Important information

HAKI's product liability and user's manuals apply only to scaffolds that are entirely composed of components that have been made and supplied by HAKI.

HAKI's scaffold systems must not be erected using components of makes other than HAKI or be connected to scaffolds of makes other than HAKI. In such cases, a special study of load-bearing capacity must be carried out. However, HAKI has no objection to the customary addition of scaffold tubes and approved couplers to the scaffold.

Adding components from different suppliers may invalidate the insurance cover.

This user's manual is based on a minimum of 2 competent erectors wearing safety harnesses with twin tail lanyards.













HAKI reserves the right to make technical modifications on a continual basis.

The latest versions of HAKI user's manuals can be downloaded from our website, www.HAKI.com.

For scaffold structures that are not covered by this user's manual, please contact HAKI's technical department.

HAKI colour code

Horizontals and diagonals are marked with their nominal sizes (bay sizes) and a colour code. The marking is a useful means of identification when erecting and handling the scaffold material.

| | | | | | | | |
|------|---|------|---|------|---|------|--|
| 564 |  | 1050 |  | 1964 |  | 3050 |  |
| 700 |  | 1250 |  | 2050 |  | | |
| 770 |  | 1550 |  | 2500 |  | | |
| 1010 |  | 1655 |  | 2550 |  | | |

Forces and dimensions

1000 N = 1 kN ~ 100 kg

10 N ~ 1 kg

All measurements in mm

HAKI Public Access Stair

Public Access Stairs are designed for loadings up to 7.5 kN/m² and are suitable for public use in line with national standards including HM Government's Building Regulations 2010.

General

The HAKI Public Access Stair (PAS) incorporates the use of many HAKI Universal system components including the base jacks, standards, diagonal braces, ledgers and landings. The stair stringers and handrails are specially designed for use on a Public Access Stair. All components are hot-dip galvanized with the exception of AL planks.

HAKI PAS are erected in bay widths of 1250 mm, 1655 mm or 1964 mm and lengths of 1655 mm or 2500 mm. Lift heights can be 0.5, 1.0 or 1.5 m. Single Ledger Beams or Ledger Beams can be used as both Transoms or Ledgers. Decking and stair treads can be installed with either Aluminium Planks or solid steel Chequer Plates.

Additional DDA compliant handrails can be installed to all HAKI PAS configurations. For more information on how to install DDA Handrails on HAKI PAS, please refer to "DDA Handrail Installation" which can be downloaded from our website www.HAKI.com.

The stair tower can be erected as a free standing entity or to be connected to a scaffold.

Marking

All components, with the exception of locking catches, pins etc, come permanently marked with the HAKI logo or HAKI text, the first letter of the country of manufacture and the last two figures of the year of manufacture (S25). All load bearing components are marked for full traceability.

| | | |
|--|---|---|
|  |  IMPORTANT! ENGAGE LOCKING CATCHES AS EACH COMPONENT IS FIXED |  |
|--|---|---|

Arrangement with Aluminium Treads

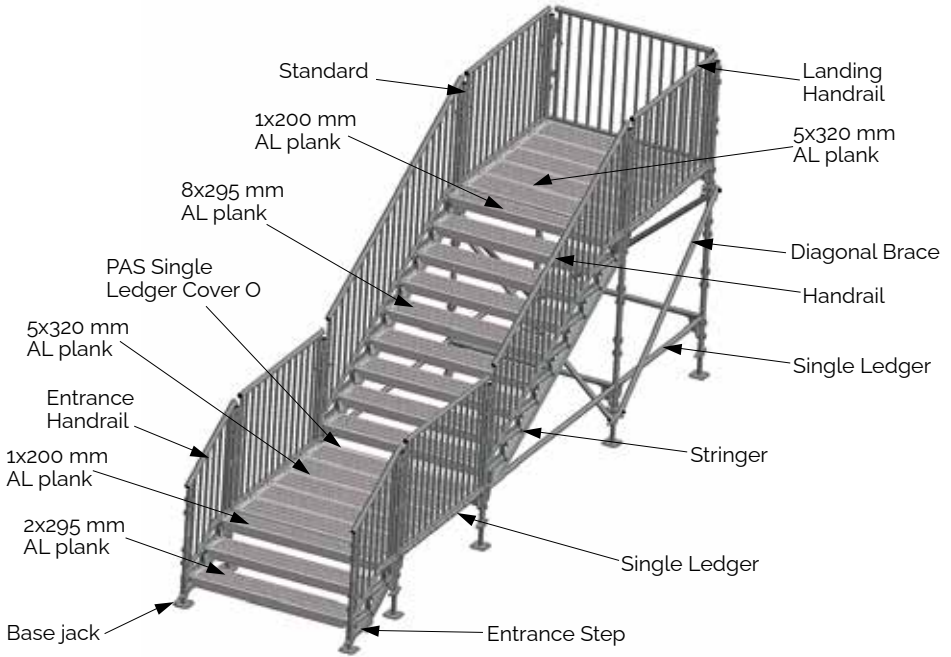

NOTE: For more information about the use of AL planks in the PAS system, please refer to "HAKI Public Stair Tower TI-sheet" which can be downloaded from our website www.HAKI.com.



Arrangement with Chequer Plate Treads







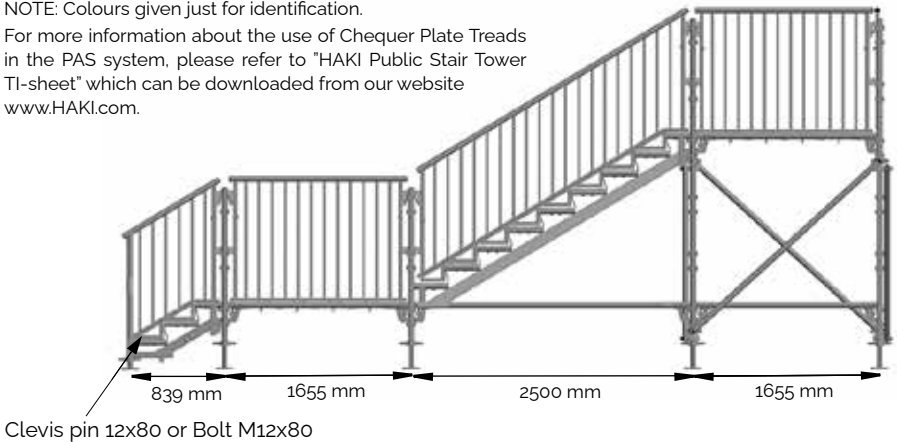









NOTE: Colours given just for identification.





For more information about the use of Chequer Plate Treads in the PAS system, please refer to "HAKI Public Stair Tower TI-sheet" which can be downloaded from our website www.HAKI.com.









Note: 1 Clevis Pin 12x80 + 1 R-Clip A-E3 or 1 Bolt M12x80 + Nut must be installed at each end of the bottom entrance step if chequer treads are used.
 - Clevis Pins NOT NECESSARY if AL treads are used.





| Name | | Code/Data | Item No. | Weight(kg) |
|--|---|---|--|-----------------------------------|
| Base Jack BS Adjustable 55-570 mm |  | | 2071000 | 5.0 |
| Standard S Standard joint with spigot Pockets at same level Ø48 mm |  | 500 1000 1500 2000 3000 | 7016050 7016100 7016150 7016200 7016300 | 2.9 5.3 7.7 10.1 15.2 |
| Open-ended Standard SC Standard joint without spigot Pockets at same level Ø 48 mm |  | 853 1353 1853 | 7011104 7011154 7011204 | 4.8 7.3 9.8 |
| Tripod With pockets on one standard Pockets at same level Ø 48 mm |  | 500 1000 2000 3000 | 7203340 7203341 7203342 7203343 | 10.0 17.3 31.8 48.8 |
| Adapter Tripod |  | Adapter tripod 60 Base jack BS 60 | 7203312 2071061 | 11.6 15.6 |
| Ledger Beam LBL With spring locking catch Ø 34 mm |  | 1250 1655 1964 2500 | 7021122 7021162 7021192 7021252 | 6.5 6.7 8.0 10.9 |

| Name | Code/Data | Item No. | Weight(kg) |
|--|-------------|----------------|------------|
| Single Ledger ERB With spring lacking catch Ø 48 mm  | 564 | 7022050 | 2.7 |
| | 770 | 7022073 | 3.6 |
| | 1010 | 7022097 | 4.3 |
| | 1250 | 7022121 | 5.1 |
| | 1655 | 7022161 | 6.3 |
| | 1964 | 7022191 | 7.3 |
| | 2500 | 7022246 | 8.9 |
| Spacer  | 300 | 7022030 | 1.5 |
| PAS Single Ledger Cover With spring lacking catch Ø 48 mm Detail O S  | 1250 O | 7104125 | 6.7 |
| | 1250 S | 7104126 | 7.2 |
| | 1655 O | 7104165 | 8.5 |
| | 1655 S | 7104166 | 8.5 |
| | 1964 O | 7104191 | 10.0 |
| | 1964 S | 7104192 | 10.7 |
| Entrance Step  | 3-step | 7102006 | 10.7 |
| Stringer  | 1655 x 1000 | 7102100 | 25.0 |
| | 2500 x 1500 | 7102150 | 34.5 |
| Entrance Handrail  | 3-step | 7058004 | 15.0 |
| Handrail  | 1655 x 1000 | 7058100 | 26.5 |
| | 2500 x 1500 | 7058152 | 36.5 |
| Intermediate Handrail  | 1655 x 500 | 7058050 | 24.0 |

| Name | Code/Data | Item No. | Weight(kg) |
|--|----------------|----------------|------------|
| Landing Handrail  | 300 | 7053030 | 7.5 |
| | 564 | 7053056 | 10.9 |
| | 700 | 7053070 | 11.9 |
| | 770 | 7053077 | 12.5 |
| | 1250 | 7053125 | 19.5 |
| | 1655 | 7053165 | 23.0 |
| | 1964 | 7053191 | 28.2 |
| | 2500 | 7053250 | 34.2 |
| Tripod Handrail  | | 7058000 | 7.1 |
| Diagonal Brace DS With wedge couplers Ø 48 mm | | | |
| DS 1250 L=1954 | 1250 | 7122124 | 9.1 |
| DS 1655 L=2235 | 1655 | 7122164 | 10.1 |
| DS 1964 L=2473 | 1964 | 7122194 | 10.9 |
| DS 2500 L=2917 | 2500 | 7122154 | 12.6 |
| AL plank  | 770x320x90 | 2153077 | 4.6 |
| | 1250x320x90 | 2153123 | 6.4 |
| | 1250x295x90 | 2153124 | 6.4 |
| | 1250x200x90 | 2153125 | 5.0 |
| | 1655x320x90 | 2153163 | 7.9 |
| | 1655x295x90 | 2153164 | 7.5 |
| | 1655x200x90 | 2153165 | 6.2 |
| | 1964x320x90 | 2153193 | 9.1 |
| 1964x295x90 | 2153194 | 8.6 | |
| 1964x200x90 | 2153195 | 7.1 | |
| Clevis Pin 12x80  | | 6130049 | 0.08 |
| R-Clip A-E3  | | 6130441 | 0.01 |

| Name | Code/Data | Item No. | Weight(kg) |
|---|----------------|----------------|------------|
| Chequer Plate Top Tread Compatible with both PAS and HBS  | 1655 | 2140162 | 17.3 |
| | 1964 | 2140192 | 20.1 |
| Chequer Plate Mating Tread  | 1655x270 | 2140161 | 18.4 |
| | 1964x270 | 2140191 | 21.7 |
| Chequer Plate Tread  | 1655x300 | 2140163 | 19.5 |
| | 1964x300 | 2140193 | 21.7 |
| Chequer Plate Deck Compatible with both PAS and HBS  | 1250x200 | 2140125 | 13.1 |
| | 1250x250 | 2140126 | 14.9 |
| | 1655x200 | 2140165 | 17.4 |
| | 1655x250 | 2140166 | 19.7 |
| | 1964x200 | 2140195 | 20.6 |
| | 1964x250 | 2140196 | 23.4 |
| | 2500x200 | 2140255 | 26.2 |
| 2500x250 | 2140256 | 29.8 | |
| Handrail Extension 3 step in a 1010mm bay Assembling see page 23  | | 7053011 | 4.6 |
| Handrail Extension from 3 step to 4 step Assembling see page 23  | 4-step | 7058002 | 7.1 |
| Additional Step for Stringer from 3 step to 4 step Assembling see page 23  | 4-step | 7102007 | 3.3 |

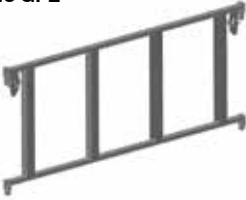
Erection Accessories

| Name | Code | Item No. | Weight(kg) |
|---|----------|-----------------|------------|
| Light Deck AL Load class 3 (2.0 kN/m ²)  | 1250x600 | 4071128 | 9.1 |
| | 1655x600 | 4071168 | 11.1 |
| | 1964x600 | 4071198 | 12.5 |
| | 2500x600 | 4071268 | 15.8 |
| Decking unit with hatch  | 1655x600 | 4071169 | 13.2 |
| | 1964x600 | 4071199 | 14.5 |
| | 2500x600 | 4071269 | 17.0 |
| HAKI Steel Deck  | 1655x230 | 21521655 | 9.7 |
| Guardrail Frame GFL  | 770 | 7052077 | 4.0 |
| | 1250 | 7052124 | 5.7 |
| | 1655 | 7052164 | 7.4 |
| | 1964 | 7052194 | 8.1 |
| | 2500 | 7052254 | 9.2 |
| Advanced Guardrail Tool  | | 4052001 | 1.4 |

For other accessories, see HAKI Component List

Information on safety when erecting and dismantling

1. Before erecting or dismantling a scaffold, the working area should be fenced off where possible.
2. The location for the scaffold must be checked in order to prevent risks when erecting, dismantling and moving the scaffold and to ensure that work can be carried out safely with regard to level and slope, obstacles and wind conditions.
3. Make sure that all lifting equipment to be used, e.g. chain hoists, lifting ropes, pulley blocks, etc., has been thoroughly tested and approved by an authorized person in accordance with local regulations.
4. Check that tools and protective equipment are available at the worksite.
5. Wear appropriate personal safety equipment at all times, e.g. safety harnesses, proper independent lifelines with suitable fixings, etc.
6. When erecting and dismantling a scaffold, robust temporary decking must be used as temporary platforms for the scaffolders.
7. Always make sure that the safety locking devices that prevent a platform lifting off have been activated once a platform has been installed.
8. Study all relevant instructions or safety directions from the manufacturers of the various scaffolds that are to be used.
9. Never climb up a scaffold from the outside. Always use the stairs, ladders or climbing frames that are designed to provide access to the upper decks from the inside of the scaffold.
10. If the scaffold is located outdoors, erection or dismantling work must be discontinued in severe weather conditions. All loose components and materials must be secured prior to leaving the scaffold.
11. All scaffolding work must be undertaken by competent operatives under the supervision of a competent person.
12. Raising and lowering of parts, material and tools using ropes or slings must be carried out in a protected lifting area.
13. Lifting equipment must not be fitted to scaffolding unless ties or equivalent devices are secure.
14. Beware of any overhead power lines nearby.
15. Always observe and comply with the regulations issued by the local authorities concerned.
16. Operatives should always be clipped to a single ledger or ledger beam during erection/dismantling. Reference should be made to the "Personal Safety Equipment" section in the HAKI Universal User manual.

Before erecting the Public Access Stair, check and flatten out the ground. The ground must be flat for even settlement of the base lift. The ground's bearing capacity may be improved with the help of sole pads.

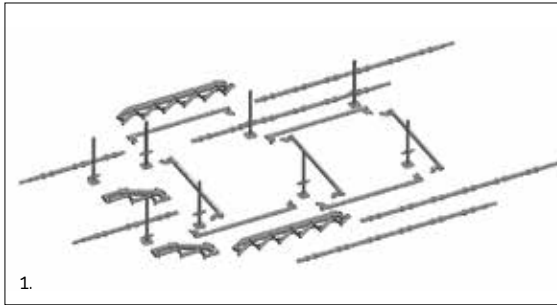

1. Lay out material to form base lift.

Position base jacks on sole pads, at the position of standards.

The 2 entrance step base jacks should be adjusted to the minimum extension. All other base jacks are to be adjusted to 165 mm above this level.

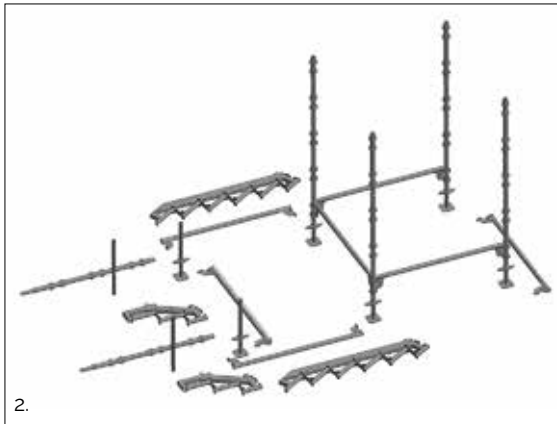

2. Install the first standard and fit single ledgers in both the transverse and longitudinal directions.

Ledgers must be fitted to the lowest group of pockets on all standards.

Lock the beams into position.

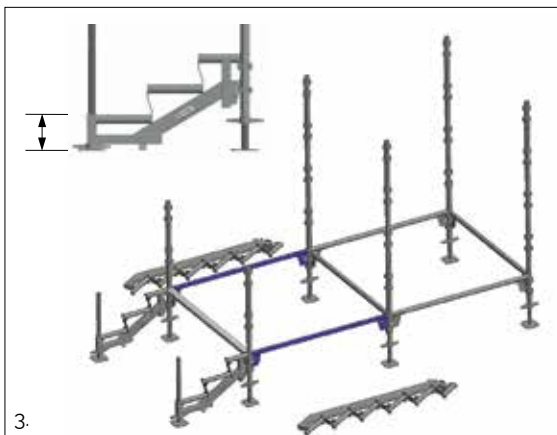

3. Install remaining standards, transoms and ledgers in order to complete the first lift.

Fit the 3 step entrance stair stringers onto the end standards.

Adjust the base jack heights to ensure the stair stringers are level and the first step is not too high.

Note: If aluminium treads are used, use a single ledger with offset cover plate at the top of the entrance steps.

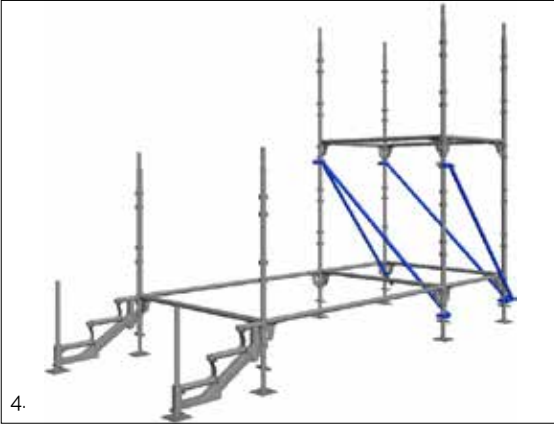

4. Install a second level of single ledgers at either 1,0 or 1,5 m, depending on the stair configuration, above the first set of ledgers.

Install diagonal braces around all 4 sides of the landing tower and correct the vertical alignment of the standards.

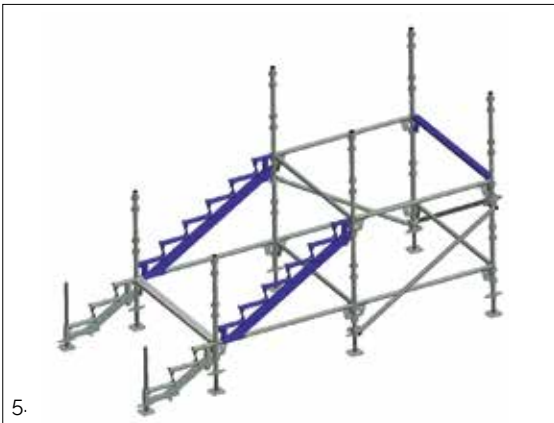

5. Install the stair stringers.

Note: If aluminium treads are used and further stair stringers are to be added, then use a single ledger with offset cover plate at the base of the next stair lift.

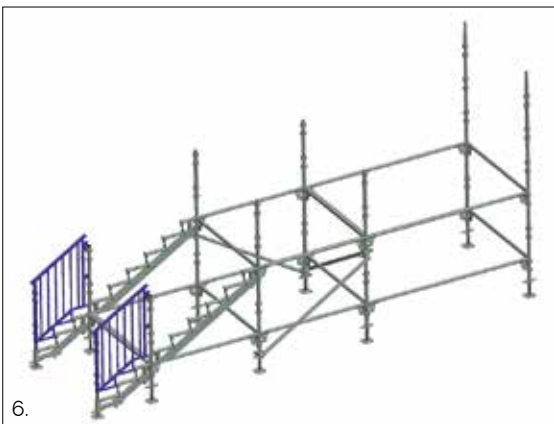

6. Install the entrance handrails into the pockets on the standard and the base jack.

Lock the handrail in the highest position to allow treads to be fitted beneath.

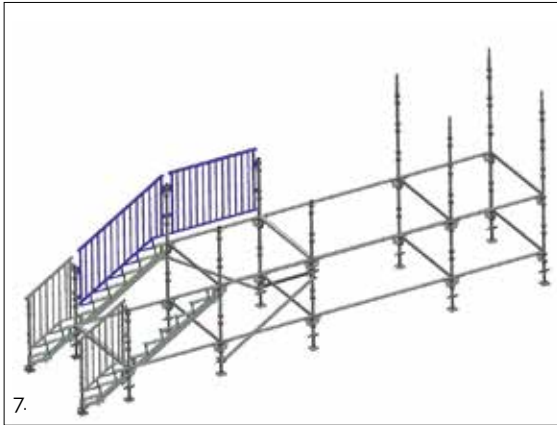

7. Fit the handrails and landing handrails in place, locked off in the highest position.

Note: The installation of decking and treads should be done before the installation of handrails and landing handrails if chequer plate treads/decks are used.

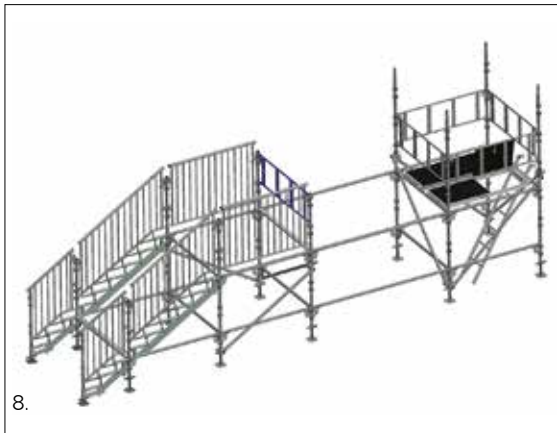

8. To continue the erection of all subsequent lifts, using the advanced guardrail tool, install guardrail frames on the 4 sides of the end tower. Engage the locking catches. Install light deck units and a ladder for access.

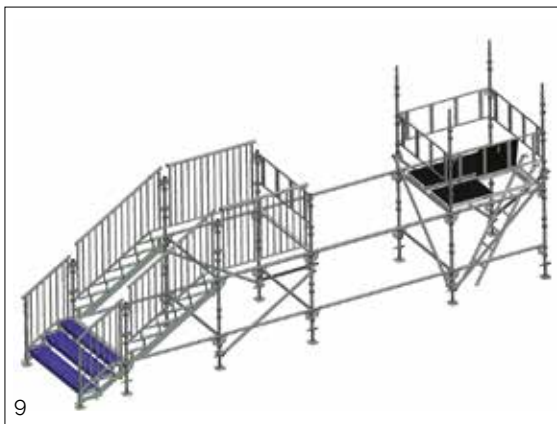

9. Install stair treads onto the stair stringers.

Note: 1 Clevis Pin 12x80 + 1 R-Clip A-E3 or Bolt M12x80 + Nut must be installed at each end of the bottom entrance step if chequer treads are used.



10.

10. Continue to fit stair treads and deck out landing.

If aluminium stair treads are used, engage the locking catches.

Chequer plate treads are held secure by the stair stringers once lowered and locked in position.

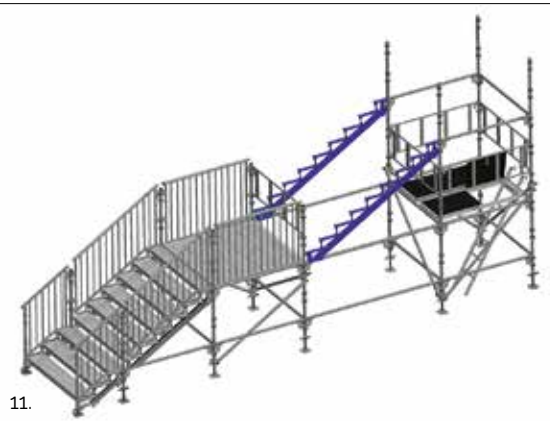

11.

11. Standing on the end tower, place the stair stringer on the single ledger and slide the stair stringer to the other side.

Install the high end of the stringer into the pockets of the standard and lock them.

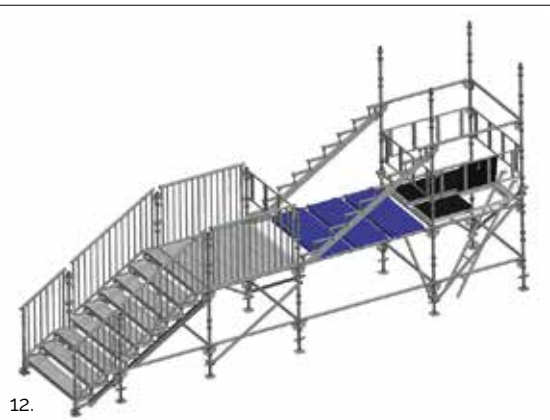

12.

12. In order to safely board out the next set of stair stringers, place decking units beneath the stair stringers on the single ledgers.

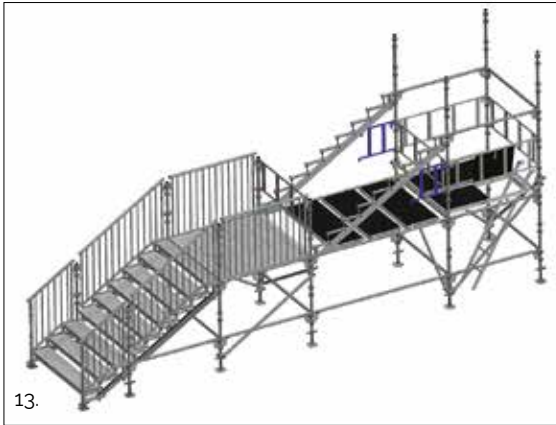

13. Install 770 guardrail frames to secure the working platform and meet collective fall protection guidelines.

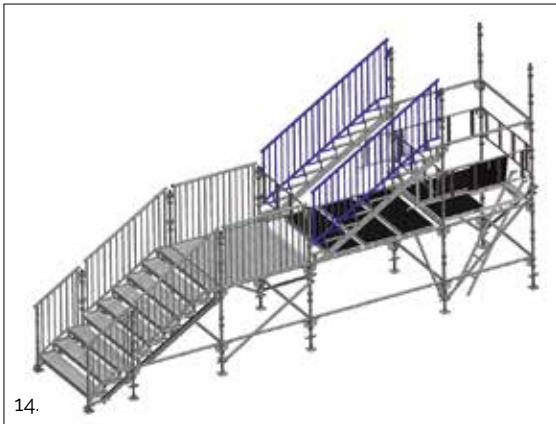

14. Install the handrails into the standards, locked off in the highest position.

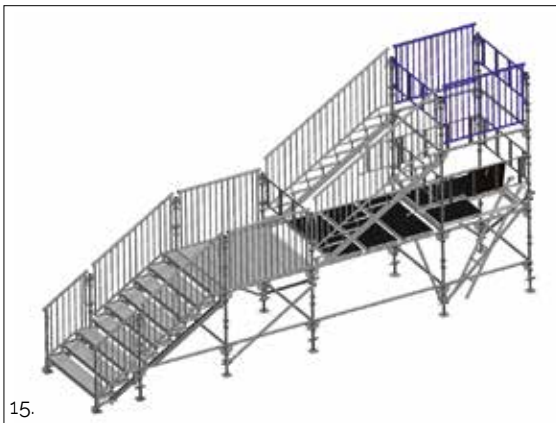

15. Install landing handrails in place, locked off in the highest position, and fit guardrail frames to enclose the end tower.

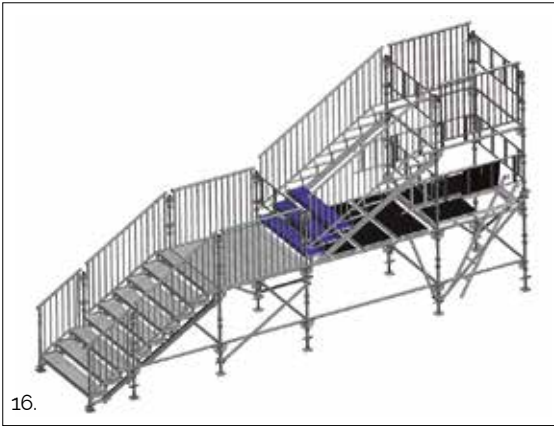

16. Deck the stair stringer half way from the lower tower.



17. Standing on the temporary decking units install the remaining treads in place.

If aluminium stair treads are used, engage the locking catches.

Chequer plate treads are held secure by the stair stringers once lowered and locked in position.

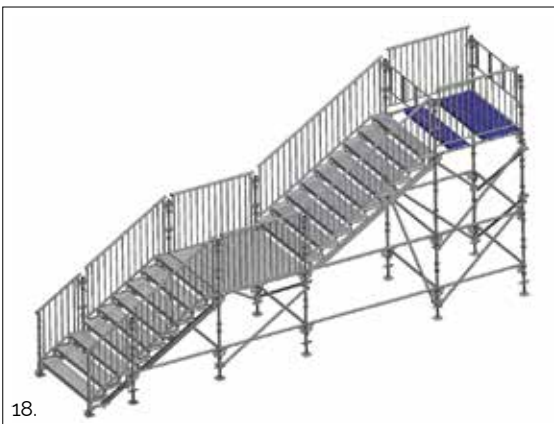

18. To deck the landing, slide each deck under the guardrail frame and landing handrails.

Once complete remove the decking units below.

Fully brace the landing tower with diagonal braces to all 4 sides.



19. Once decking is complete, all handrails and landing handrails **MUST** be dropped to their lowest position (locking all treads in place), and be secured by tightening the screw nuts, using a 22 mm ratchet spanner, at each end of the handrails.

Install any tube and fitting required to tie the public access stair to the adjacent structure. Tie the public access stair as shown on page 21.

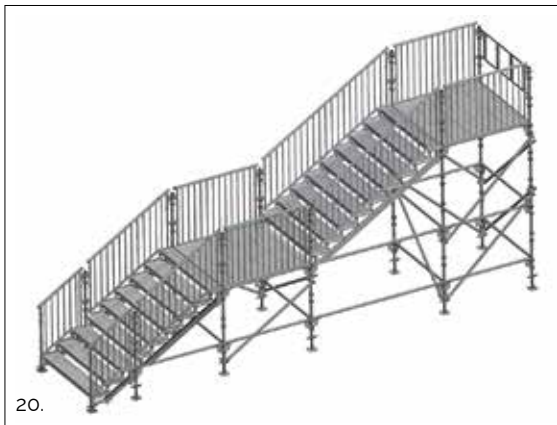

20. The basic public access stair tower is complete.

To continue the erection of a straight or spiral public access stair tower, repeat stages 8-19, adding additional lifts as required to meet the new height.

If there are requirements for treads to be covered with plywood and/or glass reinforced plastic (GRP) sheeting, then this should be carried out at this stage.

Intermediate handrail installation



1. Ensure guardrail frames are in place as a collective fall protection measure.

Install the 3 step stair stringer into the pockets of the standards and rest onto the landing ledger.



2. Insert the intermediate handrails into the standards, locked off in the highest position.

Note: The installation of decking and treads should be done before the installation of handrails and landing handrails if chequer plate treads/decks are used.



3. Slide the treads under the handrail.

If aluminium stair treads are used, engage the locking catches.

Chequer plate treads are held secure by the stair stringers once lowered and locked in position.



4. Once the tower is complete, the intermediate handrails **MUST** be dropped to their lowest position (locking all treads in place), and be fully secured by tightening the screw nuts, using a 22 mm ratchet spanner, at each end of the handrails.

Information on safety when dismantling

1. Do not throw or drop materials to the ground. This may damage the material or cause personal injury. The materials must be lowered down to the ground by means of ropes or slings or passed down by hand.
2. If intermediate ties or tie rod tubes have been installed, they must not be removed until the dismantling process reaches the level in question.
3. Always observe and comply with the regulations published by the local authorities concerned.
4. Operatives should always be clipped to a single ledger or ledger beam during dismantling.
5. Reference should also be made to section "Information on safety when erecting and dismantling" on page 11 in this manual.

Intructions for dismantling

1. Dismantle the scaffold from the topmost lift.
2. Start by raising all handrails into the higher position and lock, this will allow planks to be removed from the working platform below.
3. Remove planks from a guardrailed working platform below.
4. Remove all handrails and stringers from top lift.
5. Remove ledgers, diagonal braces and standards where possible from the top lift. Repeat stages 2-5 until the scaffold is fully dismantled.

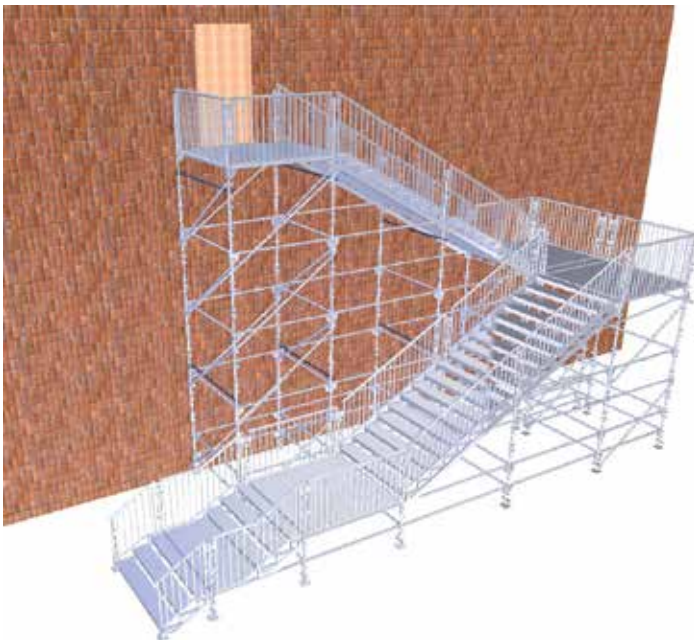

6.5 m Public Access Stair with consecutive flights

Base jacks

The Public Access Stair is erected on base jacks.

These are either $\varnothing 38$ mm or $\varnothing 60$ mm depending on whether Tripods are used or not.

Standards

Standards of lengths 3000, 2000, 1500, 1000, 1853, 1353 and 853 mm are used in the Public Access Stair. The standards must always be 1000mm higher than the next lift.

Tripods

Tripods must be used if the leg loads exceed the permissible loads for standards.

For manual handling, 3000 mm tripods should be used on the bottom lift only.

For further information please see the product information sheet for Tripods or contact the HAKI Technical Department.

Horizontal members

The Public Access Stair is erected using single ledgers with either 1,0 or 1,5 m between lifts, depending on the stair configuration.

Each landing level must be provided with horizontal members on all sides.

The bottom lift must always be fitted at the lowest possible level.

Handrails

All stair flights and landings must be provided with handrails at all outside edges.

Bracing and tying in

The Public Access Stair must be braced using vertical diagonal braces to full height on all faces of each 'landing' tower.

Where required the Public Access Stair should be tied at each standard position horizontally and at a vertical spacing of 4 m in height. The first tie level in height must not be more than 4 m from ground level.

Permissible loads

The maximum permissible load on stair flights and landings is 7,5 kN/m².

Spiral configuration

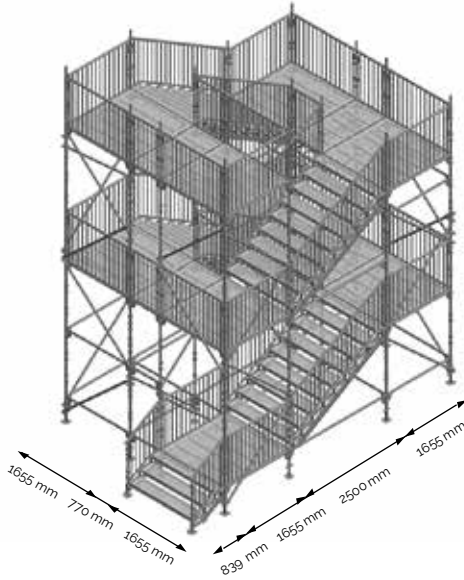

Straight configuration

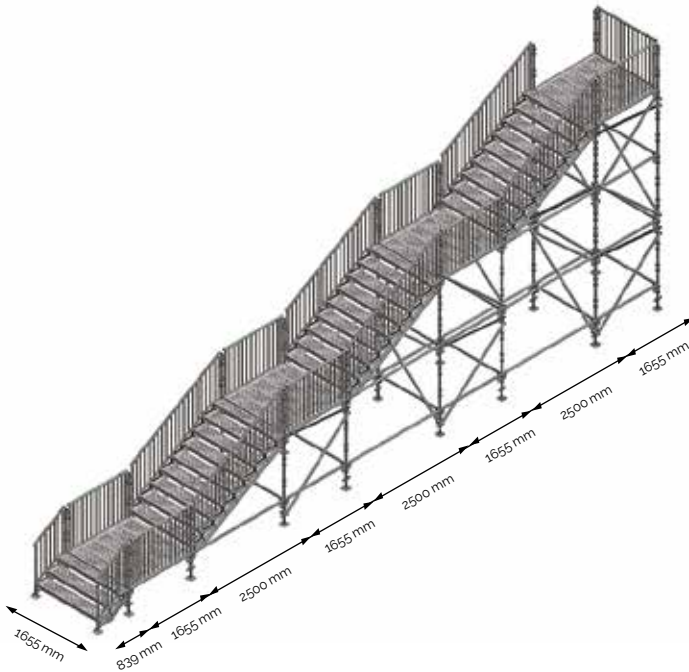

Combination of Stringer and Intermediate Handrail

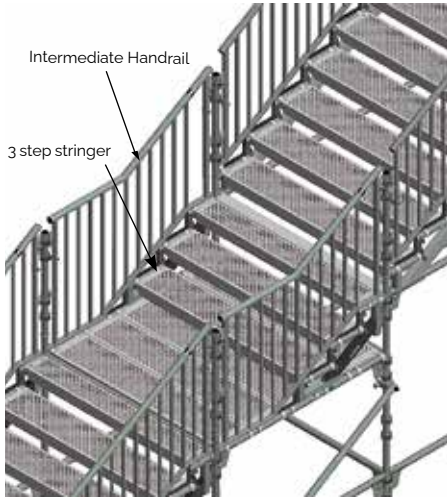

Combination of Landing and Intermediate Handrail

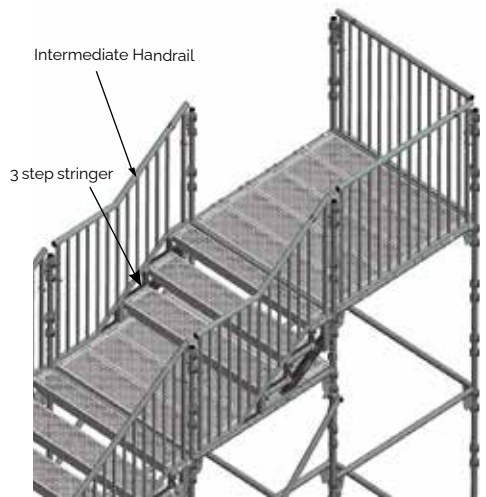

Entrance Step with 4 steps



500 mm flight in a 1010 mm bay

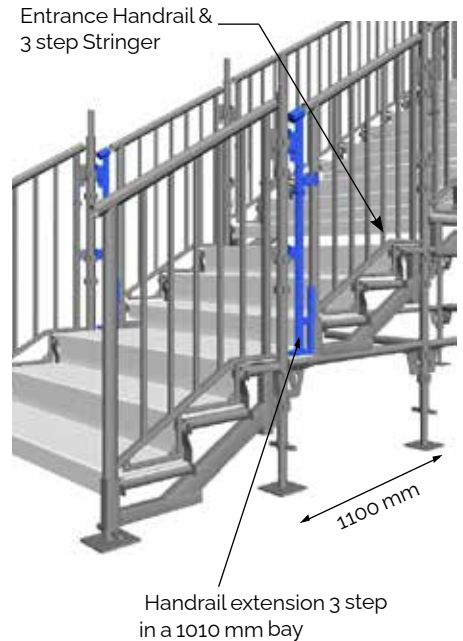

Information about DDA Handrails

Additional DDA compliant handrails can be installed when the stair tower is used for public access.

HAKI DDA handrails can be installed to all HAKI PAS configurations.

For more information on how to install DDA Handrails on HAKI PAS, please refer to "DDA Handrail Installation" which can be downloaded from our website www.HAKI.com.



Methods of erection when guardrail frame is fitted in advance



In order to be able to fit guardrail frames prior to decking, use HAKI's advance guardrail(AGR) tool (or the aid of other guardrail fitting devices).

The standards must be one metre higher than the next lift.

For other fitting devices, see HAKI Component List.

Notes



Experience

With over 60 years experience to call on, HAKI has gained a leading reputation in its field. With its own R & D and manufacturing facilities, the company now operates throughout Europe and its equipment is in use worldwide. With all products designed and manufactured to ISO 9001:2015, and a comprehensive training and support infrastructure, you can rely on HAKI for support.



Training

The Company's dedicated Training Centre is equipped with the full range of HAKI products where a comprehensive choice of courses is offered. With the benefit of this training, all users of HAKI products can be assured that the equipment is being employed safely and effectively.



Support

From computerised estimating facilities to on site assessment and project back up, HAKI is with its customers every step of the way. Working with HAKI means far more than just proven equipment, it means working with people who understand the scaffolding industry. Whatever the project, the company is committed to ensuring every user enjoys the full benefits associated with the use of HAKI - maximising the savings, profitability, and above all, SAFETY.

Health and Safety at Work Act, 1974

HAKI equipment is designed to meet the requirements of the above Act, Section 6.

It is also the customer's responsibility to comply with the requirements of this Act, particularly to use the equipment in accordance with current codes of practice and in ensuring that components are in good working condition prior to each use.

We are able to provide assistance and advice on matters relating to safe and proper use of HAKI equipment.

